

Grease Interceptor

The problem

Municipalities are stepping up efforts to limit the increasing amount of greases and oils being discharged into sanitary sewer systems. Food service facilities, in particular, are facing stiffer regulations with fines often in the tens of thousands of dollars for violations of established codes. On the federal level, the Environmental Protection Agency, through Phase II of the Clean Water Act, has also established limitations on grease discharge that could affect ground and surface water quality. Today's food service operators are quickly finding that their old, small, high-maintenance metal grease traps are ineffective because they do not perform the necessary separation of grease from the waste stream. With increased inspection from local authorities, a more effective and affordable long-term solution is required.

Most commercial and institutional kitchens have gone to using large concrete septic tanks fitted with a baffle system to improve the separation of grease from the kitchen waste stream. These modified tanks can perform the separation needed but are not ideally suited for this application because of significant deficiencies: their thin walls and mastic connections make them prone to cracking and leaking. Furthermore, concrete's porous composition tends to rapidly disintegrate when exposed to animal fats and oils, often resulting in collapse in as few as three years after installation. Metal structures have proven to be equally ineffective, as corrosion from salt-laden grease will render the internal baffles inoperative over time.

Today, a more durable and economic alternative is available.



Dependable grease removal

Advanced Drainage Systems owes much of its success to replacing failed concrete and metal with tough, chemical-resistant High Density Polyethylene. ADS corrugated HDPE pipe and structures have been installed around the world for storm drainage, and ADS now offers the sanitary sewer market its latest innovation: the Grease Interceptor.

The new solution

In 2002, ADS began developing underground structures to treat contaminated storm water to assist design engineers in meeting new and stringent EPA requirements. That successful technology has led to the development of the ADS Grease Interceptor. Incorporating a high density polyethylene body and weir plates, it efficiently removes incoming grease from kitchen waste streams before entering sanitary sewer lines without affecting the structure itself.

Better performance

When compared to concrete or metal structures, the polyethylene Grease Interceptor provides many important benefits:

- High resistance to corrosion from food waste
- Unaffected by strong acids and alkalis (operating pH range is 1.5 to 14)
- Designed to provide superior service life compared to concrete and metal
- Water-tight sanitary joints prevent wastes from infiltrating water table
- Light weight, easy to handle
- Faster installation, with a minimum of heavy equipment
- Easy cleaning through large access ports

The gravity-flow units are available in three standard capacities: 750, 1000, and 1500 gallons. A vertical weir plate divides the unit into two chambers, and contains an 8" orifice which allows lower level water to flow to the outlet. Oils and greases remain on the surface, where they are periodically removed by suction hoses through the two 30" diameter access risers.

The standard inlets and outlets are 8-inch diameter tees. If larger diameters are required, consult with ADS design engineers. Water-tight connections to the sewer line are achieved with bell-bell or bell & spigot couplers.

The Grease Interceptor meets IAPMO standards for sanitary systems, and AASHTO structural requirements. It is H-20 load rated when installed in accordance with ADS installation details, and will accept most discharges associated with commercial food preparation. For more details, refer to ADS Product Note 3.143.

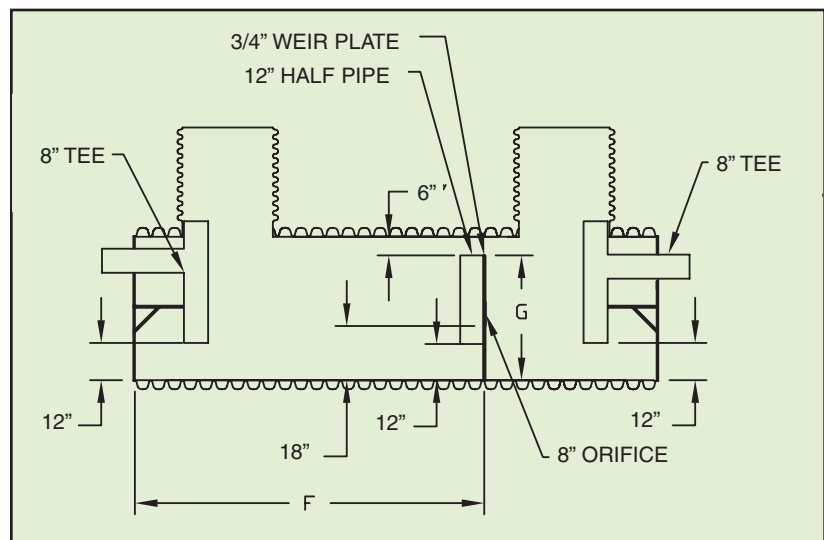
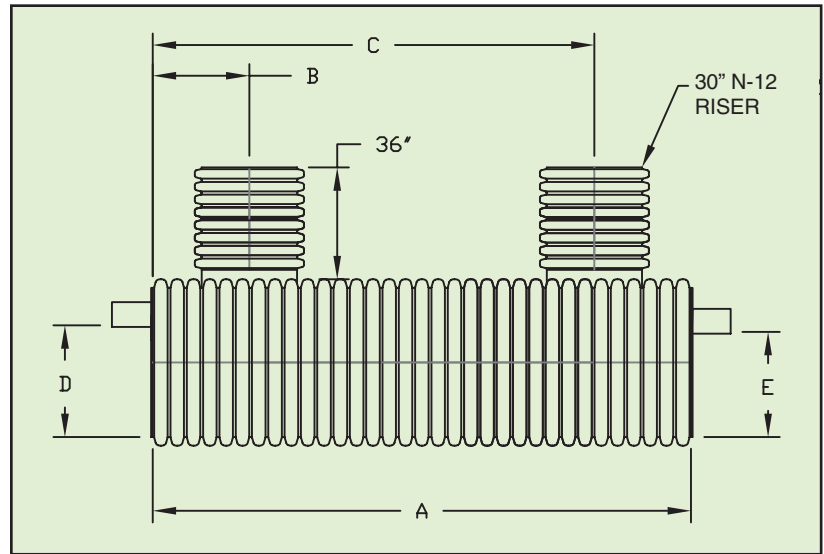

Part Number	0750ANGT	1000ANGT	1500ANGT
Volume (gal.)	750	1000	1500
Chamber Diameter	48"	48"	60"
Inlet Diameter	8"	8"	8"
Outlet Diameter	8"	8"	8"
A	131"	173.25"	156"
B	31"	31"	34"
C	100"	142"	123"
D	35.7"	35.7"	47.5"
E	33.7"	33.7"	45.5"
F	88"	116"	105"
G	41.7"	41.7"	53.5"

Installation

1. Trench and Bedding Preparation

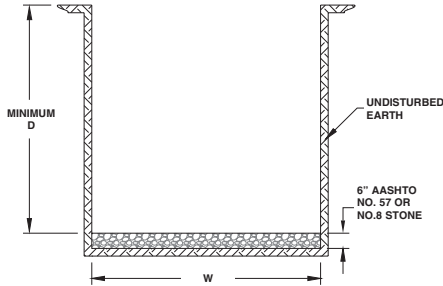

1. Dewater the trench if ground water is present.
2. Provide sheeting or shoring as required.
3. Maximum cover height measured from the top of the unit to final grade shall not exceed 8 feet.

Part No.	Min. D	Min. W
0750ANGT	5.5 ft.	7.5 ft.
1000ANGT	5.5 ft.	7.5 ft.
1500ANGT	7.5 ft.	8.5 ft.

2. Unit Placement and Initial Backfill

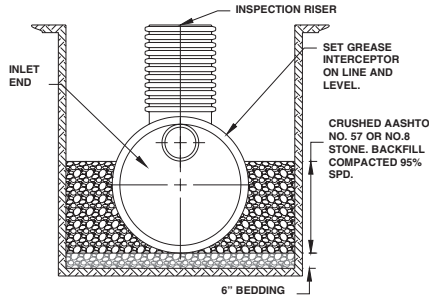

1. Utilize care when lowering unit into the trench. Handle with nylon slings and two pick points. Do not use slings around risers.
2. Place backfill around unit in uniform 8"-12" lifts compacted to 95% SPD.

3. Inlet/Outlet Connections

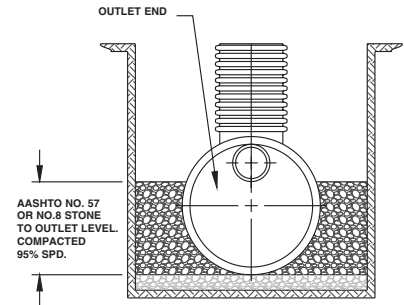

1. Start on the downstream end by connecting the outlet to the sewer line with the appropriate coupler called for on the plans. End plates will have "inlet" and "outlet" stenciled for recognition.
2. Couplers connecting the inlet and outlet shall have the same joint performance as the sewer line. Couplers may be in-line bell couplers, bell-bell couplers, or PVC to HDPE adapters as called for on the plans.

4. Inlet/Outlet Connections (cont.)

NOTE:
There is 2 inches of fall from the invert of the inlet to the invert of the outlet.

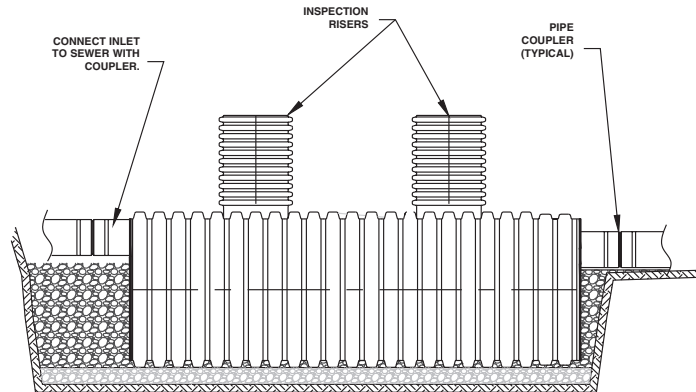

5. Backfill Around Unit

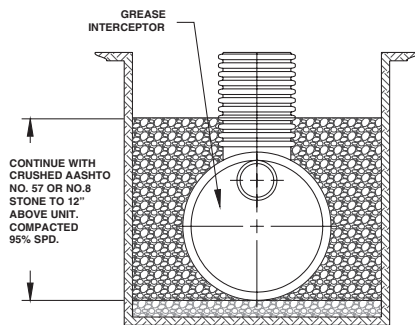

1. Continue backfill with crushed AASHTO No. 57 or No. 8 stone to 12" above body of unit.
2. Fill unit with water to the invert of the outlet pipe once backfill is placed and compacted 12" above the unit.

6. Final Cover and Riser Extensions

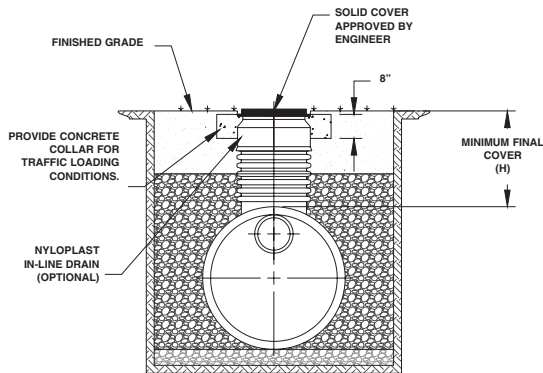

1. Please follow the installation guidelines of ADS Product Note 3.115 when installing ADS N-12® pipe on the bypass connection or in other drainage applications on the site.
2. All riser extensions to grade should be coordinated through your ADS representative.

For non-traffic and traffic loading, $H = 24"$ for all units measured from the top of the pipe to the bottom of bituminous pavement or top of rigid pavement. Maximum cover shall not exceed 96".

For traffic loading, all inspection risers shall have a traffic rated grate and load bearing concrete collar. Nyloplast in-line drain must be supported by a concrete collar so that traffic load is not transferred directly to the HDPE riser.

Leading the world in drainage technology



Over the past 40 years, ADS has spearheaded the effort to make polyethylene not only an acceptable substitute for concrete and metal, but indeed today's first choice for drainage applications. Millions of feet of N-12® pipe have been installed in municipal, industrial, commercial, and agricultural projects around the globe.

In recent years, ADS has worked closely with civil engineers, approval agencies, and environmental authorities to make the most of polymer technology in the protection and conservation of water resources. The resulting innovations include water-tight joints, underground

Retention/ Detention systems for capturing and controlling runoff, Water Quality Units for removal of contaminants from storm water, and now the Grease Interceptor for more effective operation of sanitary sewer systems.

Today, only ADS offers a truly complete system of drainage products: pipe and fittings up to 60" diameter, structures, chambers, basins, filtration units, and geotextiles, all backed by an experienced staff of engineers and field representatives to provide application and installation assistance.

ADS Sales and Service Locations

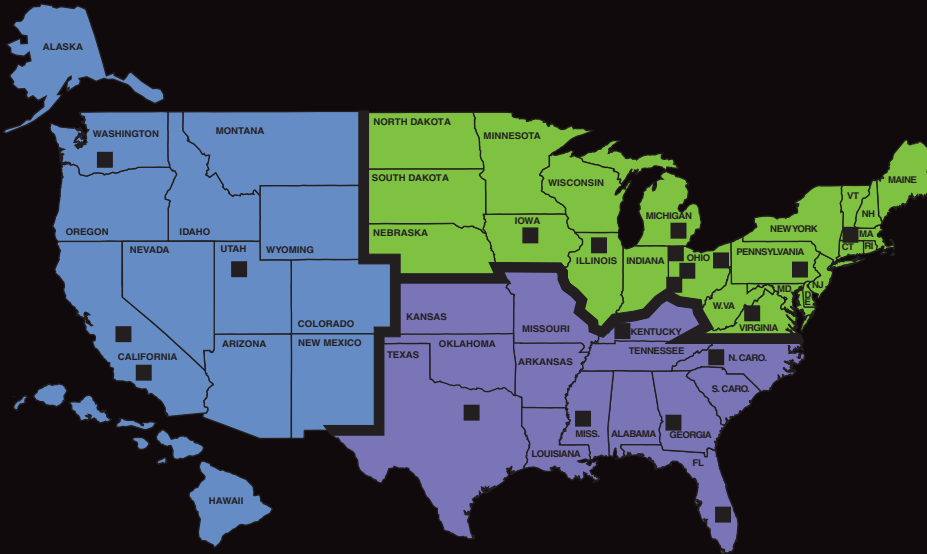

Zone Offices

- **MIDWEST/NORTHEAST**
LONDON, OH
1-800-733-9554
- **SOUTHERN**
FRANKLIN, TN
1-800-733-9987
- **WESTERN**
WASHOUGAL, WA
1-800-733-8523
- **MANUFACTURING FACILITY LOCATIONS**

To learn more about the Grease Interceptor, and the complete line of ADS drainage products, log on to www.ads-pipe.com, or call 1-800-821-6710.

ADS "Terms and Conditions of Sale" are available on the ADS website.



**THE MOST
ADVANCED
NAME IN
DRAINAGE
SYSTEMS®**



ADVANCED DRAINAGE SYSTEMS, INC.

4640 TRUEMAN BLVD., HILLIARD, OH 43026
800-821-6710 www.ads-pipe.com