

LEIT 4000 and 4000E Control Programming Quick Reference
 For technical support call 1-800-322-9146

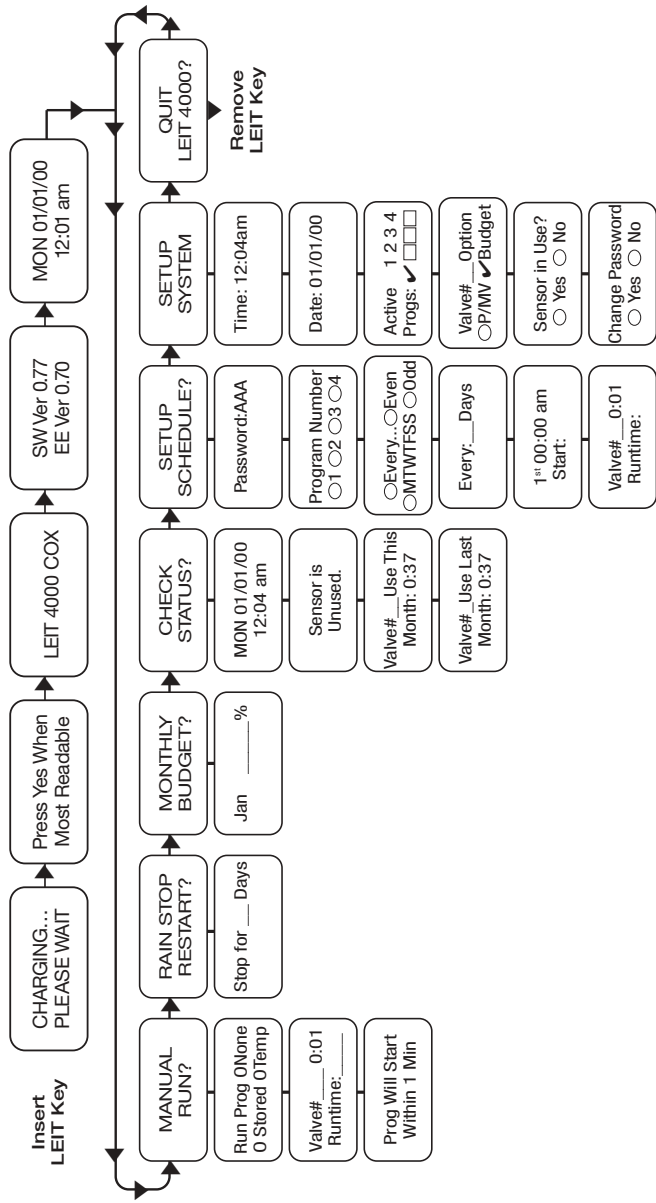

INSTRUCTION MANUAL

LEIT® Series Controllers

Installation, Programming and Operating Instructions

Models 4000 and 4000E

- Operates 4 to 16 stations
- Controller functions and operation are 100% tested
- Controller waterproof quality is 100% tested
- Controller built to the quality control standard (ISO 9002)
- Four independent programs with 3 start times per program
- Direct sunlight not required
- No batteries to maintain
- Program a 1-year water budget with one visit



TABLE OF CONTENTS

INSTALLATION

INTRODUCTION TO YOUR LEIT CONTROLLER	2
2 Parts Identification	2
3 Installation Requirements	3
4 General Installation Instructions	3
5 Wire Installation	3
6 Installation of Actuator with In-line Valve Series 150S-XXX (2-Way)	4
7 Installation of Actuator Series 1500S (2-Way)	4
8 List of Types and Models of LEMA Actuators	6
9 List of Type & Model LEMA Solenoid Actuators with Plastic In-Line Valves	7
10 Controller and Wire Installations	7
11 Installation of Sensing Application with the SKIT 8821-4	9
12 Installation of Pump or Any Electrical Equipment Using RKIT 8810S and 8810 Relay Interface Kit	10
13 Schematic Wiring Recommended for 4012E Controller	11
14 Schematic Wiring of LEMA Solenoid Actuator 4016E Controller	11
15 Maintenance	11
Visual – Controller Installation	12
Visual – Valve Installation	12
Visual – Controller Wiring	13
Visual – Sensor Installation	13

PROGRAMMING

INTRODUCTION TO PROGRAMMING	14
17 Programming 4000 Series Controller	14
18 Insert LEIT Key	14
19 Manual Run	15
20 Rainstop	16
21 Monthly Budget	16
22 Check Status	17
23 Setup Schedule	18
Select a Program Number	18
Select Watering Calendar	18
Select a Start Time	19
Select a Watering Duration	19
24 Setup System	20
To Change a Password	22
25 Service Call (Main Installation Problems)	23
26 Troubleshooting Your Controller	24
27 Warranty	27
Record Chart	28
LEIT Control Programming Quick Reference Chart	Back Cover

INTRODUCTION

Thank you for purchasing DIG's LEIT® 4000 or 4000E. The LEIT Controller you selected is one of DIG's series of "light powered" water-management irrigation controllers.

Built to the highest quality standards (ISO 9002), the LEIT series has an improved menu base with straightforward programming that allows for a wide range of irrigation programs, with features such as four programs, three start times, budgeting and more. An improved design, and our most advanced time-tested photovoltaic module which generates 14% more power, harnesses the energy of ambient light. This powers the unit day and night in any kind of weather, and offers you the best possible combination of quality and performance in the irrigation industry.

DIG LEIT controllers are available in two models: LEIT 4000 and LEIT 4000E.

LEIT 4000 SERIES

Models available: 4004, 4 stations; 4006, 6 stations and 4008, 8 stations

LEIT 4000E SERIES

LEIT 4012E, 12 stations and 4016E 16 stations

COPYRIGHT

Copyright 2001-2002 DIG CORPORATION. All rights reserved, LEIT 4000, 4000E logo are trade names, and LEIT is a trademark of DIG CORPORATION

INSTALLATION

1. INTRODUCTION TO YOUR LEIT 4000 AND 4000E

This chapter will explain the components used and the installation of the LEIT Controller. The LEIT 4000 and 4000E are ambient light-powered irrigation controllers and they must be installed according to the manufacturer's recommendations. Failure to do so will void the manufacturer's warranty. The 4000 and 4000E series controllers can be mounted on the same column.

- 1.1 The LEIT series irrigation controllers are available in either the 4000 (standard) model or 4000E (expansion) series

4000 Series (standard)	4000E Series (expansion)
LEIT 4004 4 stations plus MV/Pump	LEIT 4012E 12 stations plus MV/Pump
LEIT 4006 6 stations plus MV/Pump	LEIT 4016E 16 stations including MV/Pump
LEIT 4008 8 stations including MV/Pump	

- 1.2 If you have purchased a LEIT 4004, 4006 or 4012E, you have the option of connecting an additional master valve to your controllers
- 1.3 If you have purchased a LEIT 4008 or 4016E, you have the option to configure station 8 on 4008 and station 16 on 4016E as a master valve, when you install a master valve on your system
- 1.4 All LEIT 4000 series controllers are fitted with a wiring connector strip that has a maximum of 8 connector ports for hot wires (stations) and 2 connector ports for common wires. The 4000E series controllers accommodates the need for additional ports on its 12 station and 16 station models by modifying the standard wiring design and introducing an "expansion" LEMA solenoid actuator (please refer to wiring schemes for 4012E and 4016E on page 11 of the instruction manual)

2. PARTS IDENTIFICATION

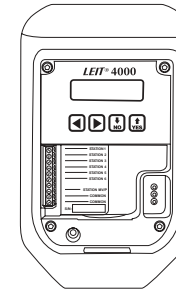

LEIT 4000

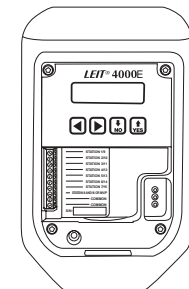

LEIT 4000E

To properly install your new controller, you will need the following:

- 2.1 Control unit: LEIT 4000 or 4000E series controllers programmed with bilingual software versions SW Ver 0.77 /EE Ver 0.70 or higher
- 2.2 LEIT Key: Programming tool required to program the controller (uses 1-nine volt alkaline battery)
- 2.3 Mounting column: model MCOL 4000 -33" (84 cm) high steel pipe including mounting tool kit (1 bolt, 1 spacer, 1 hex-key 3/16")

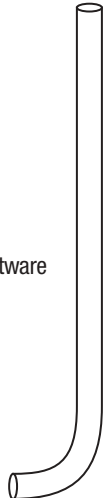
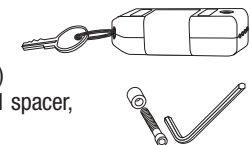

2. PARTS IDENTIFICATION...continued

2.4 Actuator can be used:

Option A: 1 each complete with a valve (150S-xxx standard series), used with controller model 4004, 4006, 4008 and 1 of each actuator complete with a valve (150S-xxx and 150E-xxx series), used with controller model 4012E and 4016E

OR Option B: LEMA actuator (1500S standard series) one for each brand name valve being used with a controller model 4004, 4006, 4008 and 1 of each actuator, (1500S and 1500E series), used with 4012E or 4016E

2.5 Optional: Model SKIT 8821-4 connector: if any sensors are used, an SKIT 8821-4 connector is required

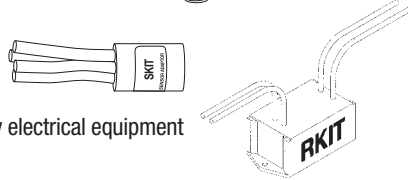

2.6 Optional: Model RKIT 8810S relay: if pumps or any electrical equipment are used, an RKIT 8810S adapter is required.

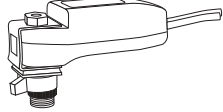
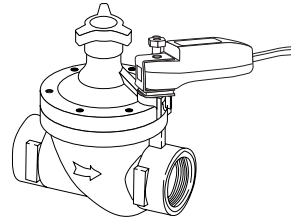

3. INSTALLATION REQUIREMENTS

Required items that you will need for the installation

1. Battery: 9V alkaline battery for the LEIT key
2. Standard wire stripper
3. Flathead screwdriver (9/64" or smaller)
4. Concrete: approximately two 60 lb (27 kg) bags
5. Conventional waterproof wire connectors

4. GENERAL INSTALLATION INSTRUCTIONS

Select the right location – the LEIT 4000 series controllers do not use AC power, you can locate the controller virtually anywhere you want.

* **Note:** all LEIT 4000 and 4000E series controllers work as well in shaded locations, such as beneath trees, as they do in full sun. **Direct sunlight is not required!**

We recommend installing a rain sensor with each controller with the use of adapter model SKIT 8821-4.

5. WIRE INSTALLATION

5.1 Run all direct burial wires along their respective trenches from each valve box to the controller location. Use selection of color coded direct burial wires to connect to each solenoid hot wire and use white wire to connect to the solenoid common wire. Make sure to label each color coded wire inside the irrigation box with the designated station number. Connect the hot wires from each LEMA solenoid actuator to one of the color coded wires using conventional dry-splice waterproof connectors. Use the single incoming common white wire to connect to the white wire of each LEMA solenoid actuator. Make sure not to exceed the maximum run recommendation of wire distance

MAXIMUM WIRE DISTANCE	
Wire gauge	Maximum run
14 AWG	1,500 feet (300 m)
12 AWG	2,400 feet (700 m)

6. INSTALLATION OF ACTUATOR WITH IN-LINE VALVE SERIES 150S-XXX (2-WAY)

Recommended version is option A, a complete valve assembly including LEMA solenoid actuator with plastic in-line valve (globe), sizes from 3/4" to 2", see Figure 1.

- 6.1 Shut off main line to the valve.
- 6.2 Install series 150S-xxx valves with the actuator according to the valve standard installation specification (See figure 1 and for more detail, see page 12).

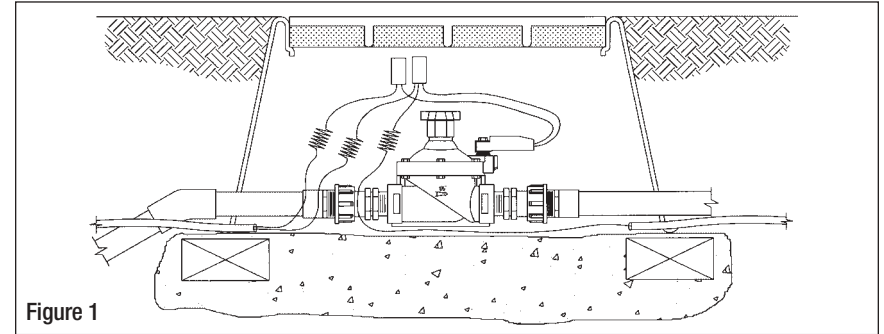

Figure 1

- 6.3 Splice the solenoid actuator wires and connect the incoming direct burial color code wire to the red wire from the solenoid actuator using dry-splice waterproof connector. Loop the incoming white common wire to the white wire from the solenoid actuator using conventional dry-splice waterproof wire connectors. Leave the wires slightly loose on each side so that repairs, if needed, can be carried out easily. See Figure 1 on and detail on page 12.
- 6.4 After installation is completed, turn the water supply on and pressurize the main line, making sure that all the valves are operating correctly. The valves will open momentarily and then shut off. Test each valve in manual operation by using the manual lever to open and close the valve, making sure that the valve is operating correctly.

Note: for wiring detail of E series actuator to controller series 4000E see detail on page 11.

Note: make sure to label each station wire with the station number if you do not use color coded wire

7. INSTALLATION OF ACTUATOR SERIES 1500S (2-WAY)

Match all versions of commercially available brass or plastic AC valves with the appropriate LEMA solenoid actuator (see list of LEMA solenoid actuators available on page 7).

- 7.1 Shut off main line to the valve.
- 7.2 Unscrew the conventional solenoids from each of the valves that you are going to use and remove the solenoid, solenoid stem, plunger, spring and "o" ring.
- 7.3 After selecting the LEMA solenoid actuator with the adapter (if needed) that is compatible with your valve, separate the actuator from the stem assembly by unscrewing the nut on the top. (See A and A1)

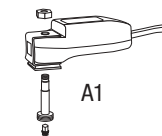
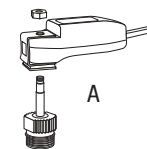

7. INSTALLATION OF ACTUATOR...continued

- 7.4 Remove adapter (if assembled) from the LEMA stem assembly and thread adapter to the compatible valve port, or screw the LEMA stem assembly into the compatible valve (See B)

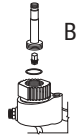

- 7.5 Screw the LEMA stem assembly into the correct adapter or valve port. Make sure the o-ring and the plunger with spring is inside the adapter or valve port. Firmly tighten the stem with a flat-head screwdriver, but do not over tighten. (See C and C1)

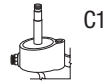

- 7.6 Slip the LEMA solenoid actuator with the magnet over the LEMA stem assembly and secure with the provided nut (see D). The nut should be tightened firmly enough so that it cannot be removed with your hand. **Do not over tighten.** Make sure to position the LEMA solenoid actuator with the label facing upwards. If you are having a problem with selecting or installing the appropriate LEMA solenoid actuator to your valve, contact:

DIG customer service at 1 (800) 322-9146

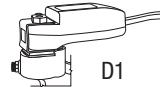
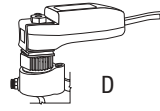

Important: do not over tighten the LEMA solenoid actuator to your valve

Caution: for all brand name valves with a manual bleed lever, make sure the lever is in closed position, and do not move the lever after installing the actuator with the valve adapter. It can damage the adapter and the valve will stay open.

- 7.6 Splice the solenoid actuator wires and connect the incoming direct burial color code wire to the red wire from the solenoid actuator using a dry-splice waterproof connector. Loop the incoming white common wire to the white wire from the solenoid actuator using conventional dry-splice waterproof wire connectors. Leave the wires slightly loose on each side so that repairs, if needed, can be carried out easily (see E).

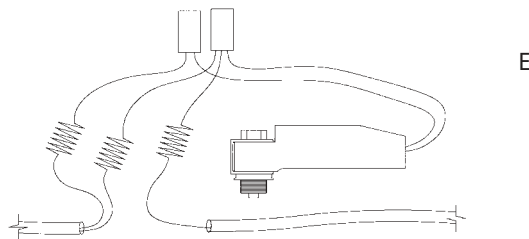

For model 4012E and 4016E run all station wires from the actuators to your splice box at the foot of the controller and label them with the correct station number. Splice one standard and one expansion actuator wire with one hot wire that will lead to the controller (e.g. 4012 station #1 + #7 or #2 + #8) please see detail on page 11.

On 4012E and 4016E controllers, an expansion actuator has to share the same wiring connector position as the standard actuator. In order for the Expansion Controller to be able to independently turn either one of these actuators on or off, (given that they both share the same hot wire), it is necessary for the expansion controller to send two different signals down the same wire. One of these digital signals will only activate a standard actuator. The other digital signal will only activate an expansion actuator.

7. INSTALLATION OF ACTUATOR...continued

- 7.7 After installation is completed, turn water supply on and pressurize the main line, making sure that all the valves are operating correctly, the valves will open momentarily and shut off. Test each valve in manual operation by using a screwdriver and turning the stem assembly counter clockwise to open and clockwise to close, making sure that the LEMA solenoid actuator selected is operating correctly.

*Note: if the valve remains open in manual operation, you may need to examine if the LEMA solenoid actuator stem and adapter are installed correctly and the nut is firmly secured. (See 7.2 to 7.6)

Note: for wiring detail of E series actuator with valve to controller Series 4000E, see detail page 11

STATION ASSIGNMENTS			
4012E		4016E	
Standard	Expansion	Standard	Expansion
Station #1	Station #7	Station #1	Station #9
Station #2	Station #8	Station #2	Station #10
Station #3	Station #9	Station #3	Station #11
Station #4	Station #10	Station #4	Station #12
Station #5	Station #11	Station #5	Station #13
Station #6	Station #12	Station #6	Station #14
	MV/P	Station #7	Station #15
		Station #8	Station #16 or MV/P

Note: make sure to label each station wire with the station number if you do not use color coded wire.

Note: Please note that the LEMA solenoid actuator operates only with 2-way normally closed valves

Warning: LEMA solenoid actuators must not be tested with any AC valve tester or DC tester over 9V! To do so will cause irreparable damage to the LEMA solenoid actuator and the controller unit and will void the warranty on the products.

8. LIST OF TYPES AND MODELS OF LEMA ACTUATORS

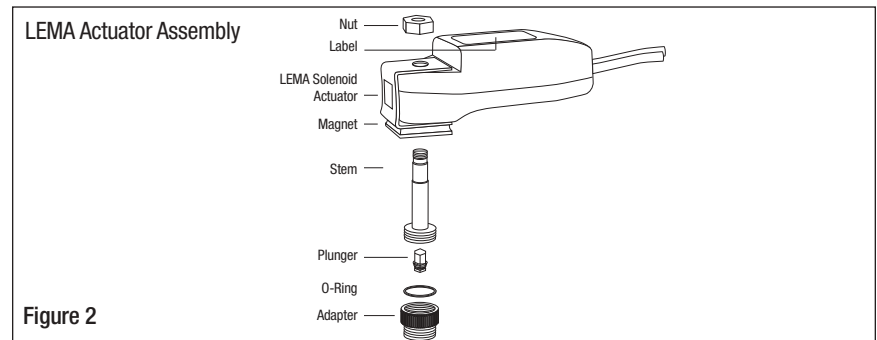

8. LIST OF TYPES & MODELS OF ACTUATORS...continued

To make sure that you are using the right LEMA actuator for your valve type and model, please refer to the list below

Model	Description
LEMA 1520S / LEMA 1520E:	For Bermad, Buckner VP, (except Imperial), Royal Coach and Toro valve in head
LEMA 1521S / LEMA 1521E:	For Rainbird DV, DVF, PGA, PEB, GB, EFB, BPE series, brass and plastic valves
LEMA 1524S / LEMA 1524E:	For Weathermatic valves
LEMA 1526S / LEMA 1526E:	For Toro 252 valves (1-1/2" and larger)
LEMA 1527S / LEMA 1527E:	For Griswold valves
LEMA 1528S / LEMA1528E:	For Imperial (by Buckner) Superior valves after Oct. 98 and Champion / Superior manual valve adapters except for EA models
LEMA 1529S / LEMA 1529E:	For Richdel & Hardie (IRRITROL) valves
LEMA 1530S / LEMA 1530E:	For Nelson Pro 7900 valves
LEMA 1531S / LEMA 1531E:	For Toro Flo Pro valves

Note: You can identify the actuator type by the label on the actuator body (1500S or 1500E series) and the model of the actuator by the label on the metal bracket, showing two digits (e.g. "21" for a 1521S or 1521E).

9. LIST OF TYPE AND MODEL LEMA SOLENOID ACTUATORS WITH PLASTIC IN-LINE VALVES

9.1 Light energized micropower standard actuators with plastic globe valve with flow control

150S-075 Standard solenoid actuator on 3/4"

150S-100 Standard solenoid actuator on 1"

150S-150 Standard solenoid actuator on 1-1/2"

150S-200 Standard solenoid actuator on 2"

9.2 Light energized micropower expansion actuators with plastic globe valve with flow control

150E-075 Expansion solenoid actuator on 3/4"

150E-100 Expansion solenoid actuator on 1"

150E-150 Expansion solenoid actuator on 1-1/2"

150E-200 Expansion solenoid actuator on 2"

10. CONTROLLER AND WIRE INSTALLATION

10.1 Install mounting column: set the curved bottom of the mounting column in a 12" x 12" x 12" (30 x 30 x 30 cm) frame and pour in the two 60 lb (27 kg) sacks of cement (See Figure A)

Make sure the column is vertical and the opening in the curved bottom is accessible and unclogged.

All wire will route to the controller through the bottom of the mounting column.

Note: make sure the cement pad is dry before continuing with the installation

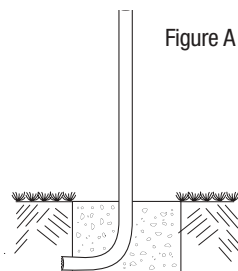

Figure A

10. CONTROLLER & WIRE INSTALLATION...continued

10.2 Run the field wires along their respective trenches from the valve box up to the bottom end of the mounting column. Make sure not to exceed the maximum recommendation of wire distance (See chart of maximum wire distance on page 3).

Push the wires up through the column until at least 12" (30 cm) of wire extends from the top of the mounting column. (See Figure B)

Note: for model 4012E and 4016E; we recommend maximum of 8 hot wires and 2 common wires should enter the column, all splicing of hot wires should be done in splice box at the foot of controller and before entering the column.

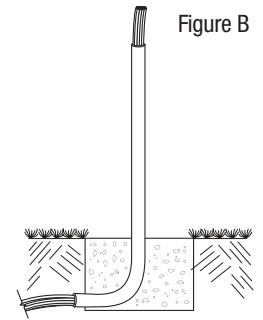

Figure B

10.3 Remove the front door from the LEIT series controller using the key (door key included) and slide the controller into place on top of the mounting column. Make sure that the 12" (30 cm) of wires are now inside the controller and cannot slip back down into the column. (See Figure C)

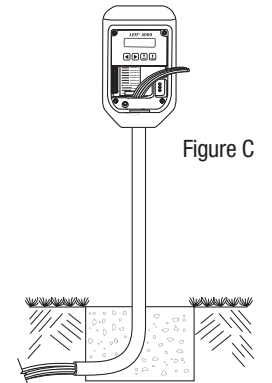

Figure C

10.4 Insert the clamp spacer and the bolt (both included with the mounting column) into the hole located on the lower left side of the controller. Tighten the bolt with the hex-key (included) until the controller does not turn or twist and cannot be pulled off of the mounting column. (See Figure D)

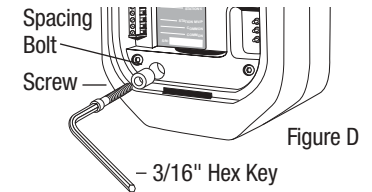

Figure D

10.5 Connect the station wires to the controller by using a standard wire stripper. Strip 3/10" of insulation from the tip of each of the station wires and connect the color coded (hot) wires into the connector strip labeled with the station number and tighten the connector screw with a screwdriver. Connect the white (common) wire into either of the two common wire connectors labeled "common" located at the lower part of the connector strip and tighten the connector screw with a screwdriver. If you are using a master valve, you have to connect the hot wire from the Master Valve into the station labeled "MV/P" (See Figure E). For pump or other electrical equipment, see detailed installation on page 10.

For detailed installation of controller and controller wiring, see pages 11-13.

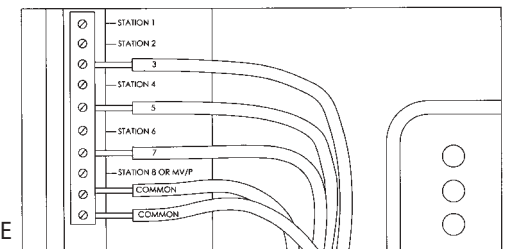

Figure E

11. INSTALLATION OF SENSING APPLICATION WITH THE SKIT 8821-4

The SKIT switch-type sensor adaptor provides a quick, reliable, weatherproof way to connect compatible rain, freeze, moisture and other normally closed switch-type sensors directly to the LEIT series controllers, to the 150S, 150E series valve assembly or to 1500S and 1500E micro-power actuator. Either way, a SKIT 8821-4 is required to connect any type of sensor to the system. (See Figure F)

11.1 OPTION 1: You can connect a sensor to any unused station on your LEIT Controller or to the controller MV/P, using a SKIT 8821-4. (See detail of Rain Sensor Installation on page 13)

Procedure: Run a red (hot) wire from the unused station or the MV/P terminal connector on your LEIT controller to the red (hot) wire on the SKIT 8821-4. Then run a white (common) wire from the common terminal connector on the LEIT controller to the white (common) wire on the SKIT. Then splice the two SKIT black wires to the sensor's two normally closed (N/C) wires. (See Figure F, option 1)

11.2 OPTION 2: You can connect a sensor to the 150S-xxx in-line globe valve or 1500S Actuator using SKIT 8821-4. If a station is not available, to minimize excessive wire runs, or if the sensor location is too far from the controller, use the SKIT 8821-4 to connect one of the LEMA series actuators at a valve closest to the desired sensor location.

Procedure: Choose a valve that is closest to your sensor location. Splice the red (hot) wire to the SKIT's red (hot) wire and to your hot field wire, creating a 3-wire connection. Then splice the LEMA's white (common) wire to the SKIT's white (common) wire and make another connection to your common field wire. Then splice the two SKIT black wires to the sensor's two normally closed (N/C) wires. (See Figure F, option 2)

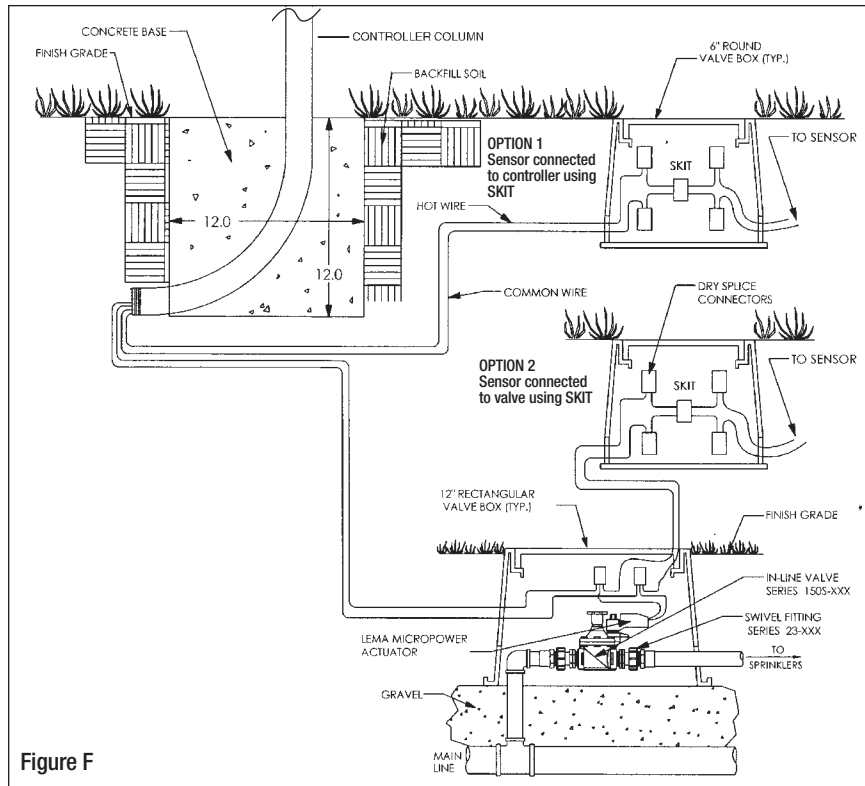

Figure F

23. INSTALLATION OF SKIT 8821-4...continued

Sensors compatible with the LEIT irrigation system:

Recommended rain sensors: Weathermatic 950 and the Hunter Mini-Clik II, Model 502.

Recommended moisture sensors: Irrrometer RA and TGA series.

Recommended freeze sensor: Hunter Freeze-Clik, Model 401.

12. INSTALLATION OF PUMP OR ANY ELECTRICAL EQUIPMENT USING RKIT 8810S AND 8810 RELAY INTERFACE KIT

The RKIT units are used to switch a 2 amp electrical circuit at a voltage of up to 240V AC/DC.

Use model RKIT 8810S with Series 4000 and all standard terminal on 4000E. Use model RKIT 8810E with expansion terminal on Series 4000E.

12.1 If you are required to switch ON a pump, fertilizer injector, fountain or light using a LEIT series controller, you have two connection options using the RKIT 8810. (See Figure G)

OPTION 1: You can install the RKIT to the MV/Pump terminal, to operate all valves with the unit that you are connecting to (e.g. pump).

OPTION 2: You can install the RKIT to one of your valve station terminal connectors to operate only the valve station number that RKIT has been installed to (e.g. Fountain will turn on/off by only the station that is using the RKIT).

To install the RKIT, run a red (hot) wire from the RKIT to any of your controller station terminals, if you wish to operate only this station. Then run a white (common) wire from the RKIT to the common terminal connector or if not available, splice it into your common field wire using a waterproof connector.

Run the two black wires from the RKIT to your AC/DC equipment and connect them to the corresponding circuit to be switched (e.g. pump start relay).

Make sure to use waterproof dry-splice connectors for all connections.

Note: If the RKIT is connected to any circuit higher than 24 volts, it must be located in its own high voltage junction box in accordance with local electrical code.

RKIT must not be housed in the same box with any low voltage equipment.

Do not connect the RKIT to a circuit higher than 240 volts.

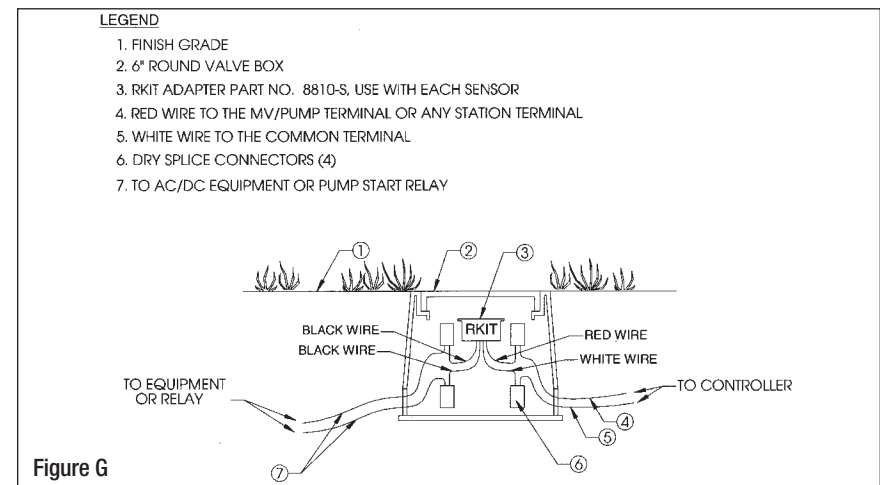
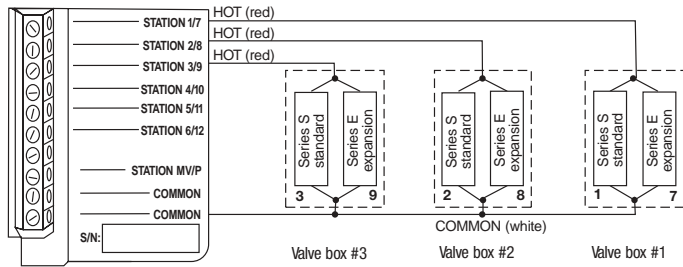

Figure G

13. SCHEMATIC WIRING RECOMMENDED FOR 4012E CONTROLLER

Option 1



Option 2

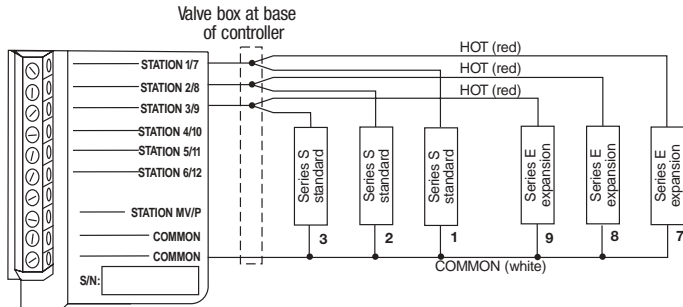

14. SCHEMATIC WIRING OF LEMA SOLENOID ACTUATOR 4016E CONTROLLER

Option 1

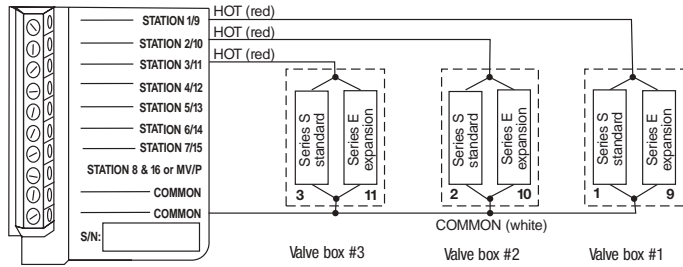

Option 2

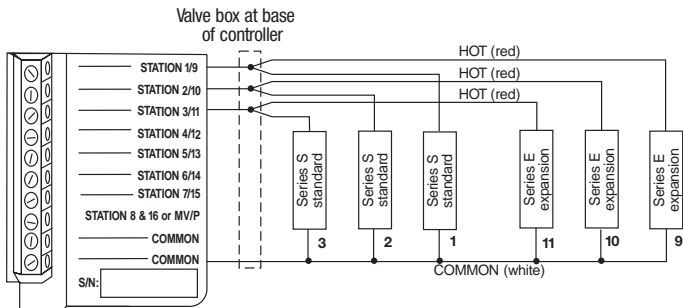

15. MAINTENANCE

None

CONTROLLER INSTALLATION

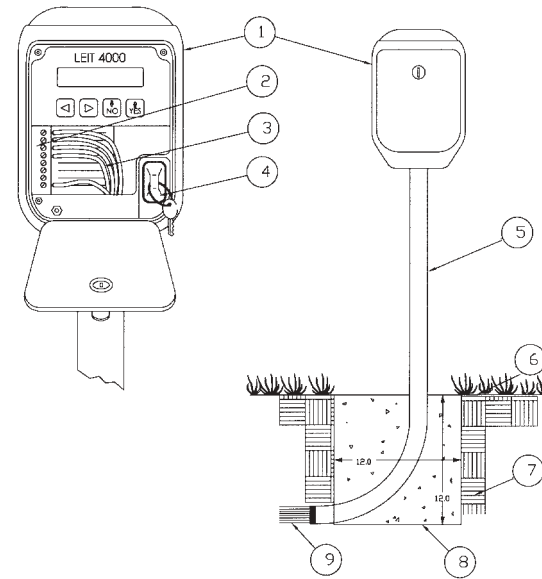

LEGEND

1. AMBIENT LIGHT POWERED IRRIGATION CONTROLLER.
2. TERMINAL STRIP.
3. 12 OR 14 GAUGE WIRE.
4. PROGRAMMING KEY.
5. 35" STEEL MOUNTING COLUMN.
6. FINISH GRADE.
7. 6-1/2" OF BACKFILL SOIL.
8. POURED CONCRETE BASE- 1-1/2 CU.FT. INSTALL PER MANUFACTURER'S INSTALLATION GUIDE.
9. DIRECT BURIAL CONTROL WIRES TO CONTROL VALVES.

1 LIGHT ENERGIZED IRRIGATION CONTROLLER
LEIT 4000

VALVE INSTALLATION

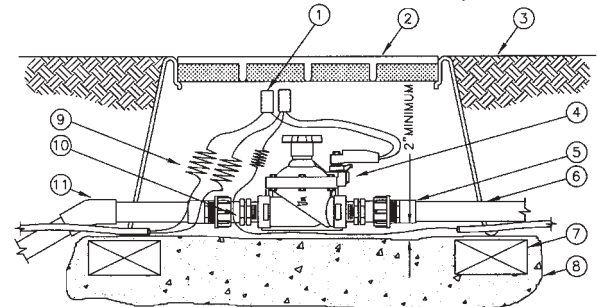

- 1 DRY SPLICE CONNECTORS
- 2 VALVE BOX WITH COVER 12" SIZE
- 3 FINISH GRADE TOP
- 4 DIG REMOTE CONTROL VALVE WITH FLOW CONTROL AND LEIT DC SOLENOID
MODEL: 150S-150 1-1/2"
MODEL: 150S-200 2"
- 5 PVC SCH 40 MALE ADAPTER
- 6 PVC MAIN LINE
- 7 BRICK SUPPORT AT EACH CORNER
- 8 PEA GRAVEL SUMP
MINIMUM 3"
- 9 CONTROL WIRE TO OTHER VALVE
- 10 SWIVEL FITTING FOR EASY CONNECTION
MODEL: 23-152 1-1/2"
MODEL: 23-202 2"
- 11 PVC SCH 40 45 DEGREE ELL

2 150S-150-200 1-1/2" AND 2" REMOTE CONTROL
VALVE ASSEMBLY

CONTROLLER WIRING

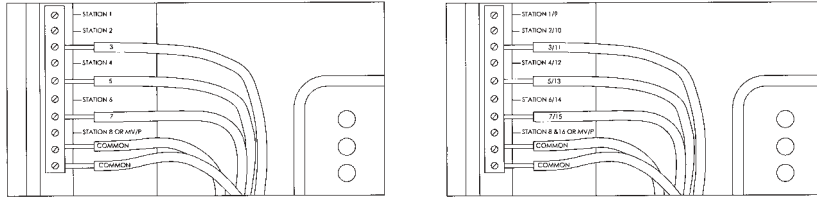

WIRE LAYOUT
LEIT 4000

WIRE LAYOUT
LEIT 4000 E

3

WIRE LAYOUT

LEIT CONTROL 4000 AND 4000E

SENSOR INSTALLATION

LEGEND

1. "MINI CLIK" RAIN SENSOR.
2. DIG PLASTIC PIPE CAP
1" CAP PART NO. 23-001 OR 1.5"
CAP PART NO. 23-153 WITH
HOLE FOR WIRES.
3. DRILL TWO 3/16 HOLES IN PIPE
FOR SENSOR BRACKET.
4. (2) #8-32 MACHINE SCREWS
WITH WASHER, LOCK WASHER
AND NUT.
5. 1" OR 1.5" GALVANIZED PIPE
6 TO 10 FEET HIGH.
6. 12"x12" CONCRETE BASE
8" DEEP MINIMUM.
7. 1" OR 1.5" PIPE ELBOW.
8. FINISH GRADE.
9. 6" ROUND VALVE BOX.
10. PART NO. SKIT
ADAPTER 8821-4
USE WITH EACH SENSOR.
11. TO CONTROLLER
OR VALVE.
12. (4) DRY SPLICE
CONNECTORS.
13. NORMALLY CLOSED
WIRE FROM SENSOR.
14. COMMON WIRE FROM SENSOR.
15. 1" OR 1.5" NIPPLE.
16. GRAVEL.

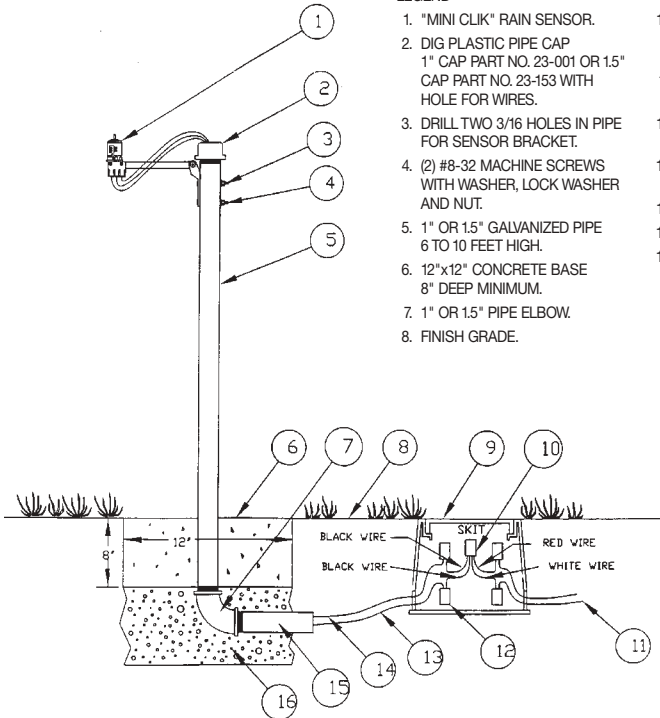

4

RAIN SENSOR ASSEMBLY COLUMN MOUNTED

PROGRAMMING

16. INTRODUCTION TO PROGRAMMING

This chapter will explain the use of the program, the features of the buttons and the application flow on your controller.

To program the controller you need to first insert the LEIT KEY, that charges the controller, and allows you to store and review the program. If you need to program the controller with only one program go to Setup Schedule. There you can select a program number, watering calendar, start time, duration and more. For more information, see the back page of this book for a Quick Reference chart of the programming flow. To move between applications (left to right) use the right or left arrow buttons and to enter an application (moving up) use the YES button.

17. PROGRAMMING 4000 SERIES CONTROLLER

The controller is programmed with the aid of 4 buttons

- Button: Use to move the cursor left
- Button: Use to move the cursor right
- Button: Use to (decrease) lower the value of the selected parameter
- Button: Use to accept, select the desired programming mode and (increase) raise the value of the selected parameter

18. INSERT LEIT KEY

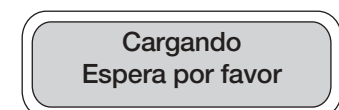
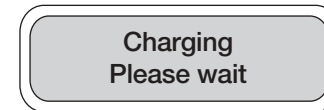

The above screens will appear only if the LEIT 4000 controller is not fully charged.

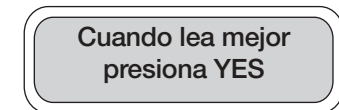
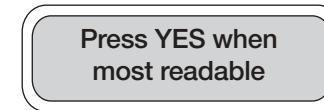

Above screens will appear alternating. Press when the language you wish to use appears on the display and the readability is best.

This screen will appear, this screen identifies your controller model.

Press

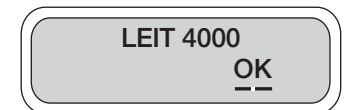

This screen identifies the software versions that are installed in your LEIT 4000.

Press

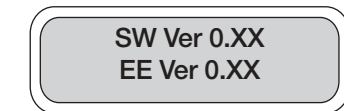

If the LEIT 4000 is being programmed for the first time, it will not display the correct time and date. Don't worry, you will correct it later.

Press for now.

19. MANUAL RUN

This option will operate any valve for a defined irrigation period. The valve will close automatically at the end of the irrigation period. Note that the originally programmed irrigation schedule will continue to function at the set time programmed. Manual Run is useful for checking the proper operation of your stations (especially after installation) and for applying additional water as required.

Manual run feature overrides any sensor control, but not budgeting.

Press to select Manual Run or skip manual run and move to the next option by pressing or .

**MANUAL
RUN?**

You have the option to run any of the stored programs (assuming that they have been programmed) or to set up and run a temporary program. For example to set a temporary program, underscore temp by pressing or and select temp by pressing , then press or button again and underscore OK, press and the next screen will appear.

Run Prog. None
 Stored Temp OK

Press or to underscore the hour or minute digits, then press or to adjust the runtime. When finished, press or to underscore OK and press to continue. Follow the same procedure for the remaining valves. To skip any valve, simply set the runtime to 0 and press to continue. In this option you will need to pass through all the valve numbers.

Valve #1 0:01
Runtime: OK

Press to start the Manual Run, (and, if you're within the spray area, remove the LEIT Key, replace and lock the LEIT 4000 door to protect the controller and move!)

LEIT 4000 will start the manual run in approximately one minute and will run each valve for the programmed duration.

Prog Will Start
Within 1 Min. OK

To STOP the Manual Run prematurely, re-insert the LEIT Key, press until you see the Manual Run display. Press again to view the "Stop Manual Run" screen.

Select Yes by pressing or and press then underscore OK and press , the following screen will appear.

Stop Manual Run?
 Yes No OK

19. MANUAL RUN...continued

Ok is underscored, press and the manual run will stop within 60 seconds. The screen will return to the Manual Run menu.

Prog Will Stop
Within 1 Min. OK

Press to continue to the next step

20. RAINSTOP

This option used to temporarily suspend all irrigation programs

For example, during rainy weather, you can stop regularly scheduled programs from watering for periods from 1 – 99 days using the Rain Stop feature. At the end of the designated period, regularly scheduled programming will resume watering automatically.

At this display, press .

**RAIN STOP /
RESTART?**

Underscore the number of days required for rain delay by using or and press or to enter a rain stop setting from 1 to 99 days. Press to underscore OK and press to continue. Rain Stop will cancel itself automatically after the number of days the program was suspended have passed.

Stop for 00 Days
 OK

You can manually cancel the Rain Stop anytime by re-entering the Rain Stop display. Once there, just press to reach the following display:

Make sure Yes is selected, by using or underscore OK and press . This will bring you back to the Rain Stop / Restart screen. Press to continue to the next step

Cancel Rain Stop?
 Yes No OK

21. MONTHLY BUDGET

Instead of changing duration for each program, you can use the Monthly Budget feature to increase or decrease the amount of water used during seasonally dry or wet periods on a monthly basis. Budget adjustments can range from 10% to 200% of your set time in 10% increments. The LEIT 4000 will automatically adjust the programmed duration for each valve according to the entered Budget per month.

At this display, press .

**MONTHLY
BUDGET?**

21. MONTHLY BUDGET...continued

Press the or button to underscore the percentage digits, press the or to increase or decrease the percentage (in increments of 10%). Then press the or button to underscore OK and press to advance to the next month.

JAN Budget: 100% OK

Repeat this procedure to enter the desired Budgets for the remaining months. To skip a month, simply press . In this procedure you will need to pass thru the 12 months to return to Monthly Budget. You can enable or disable your stations to be budgeted in the Setup System menu (see page 8).

Press the to continue to the next step.

22. CHECK STATUS

This feature allows you to review the unit's time, date and sensor setup. Status also reports the current month's watering time totals for each station as well as those for the previous month.

1. Press .

CHECK STATUS?

Reports on current date and time of day.

2. Press to review sensor setup.

SAT 01/01/00
12:04 am OK

Reports on sensors currently in use, if any.

3. Press to review valve number current month uses.

Sensor is Unused. OK

Reports how much time was logged on each of your valves during the current month.

4. Press to review the individual log for each valve.

Press after the last valve report to review the previous month log for each valve.

Valve # Use This Month: 0:37 OK

22. CHECK STATUS...continued

5. Reports how much time was logged on each valve during the previous month. Press to review the individual log for each valve. Press after the last valve report to return to the Check Status screen.

Valve # Use Last Month: 3:50 OK

Press the

23. SETUP SCHEDULE

This feature allows you to schedule up to four separate programs for each station, each with up to three individual start times per day.

Press to enter the password screen.

SET UP SCHEDULE?

Passwords are provided to give the user security against unauthorized changes being made to the system. If you are programming the controller for the first time the default password is (AAA). If you wish you can customize your password in the System Setup.

For now underscore OK and press to go to the next step.

Password: AAA OK

For example if the controller has been programmed with new password (ABC), to enter your password, press or to underscore the first letter and press or button to select A. Repeat the step for each letter, then underscore OK by using or and press to go to select a program number.

Program # 1 is a default program. To select additional programs underscore the program number by using or and press , then press or to underscore OK and press again to select the program type in the next screen.

Note: Program will not run unless you activated the program number in the system setup.

Program Number:
 1 2 3 4 OK

Program type options include:

Every- lets you operate stations from once a day to once every 39 days.

Even- every even-numbered day

Odd- every odd numbered day

MTWTFSS- lets you select specific day(s) of the week to irrigate.

Every.. Even
 MTWTFSS Odd

24. SETUP SYSTEM...continued

In this step, up to four independent programs can be activated. Number 1 is factory activated (checked), to enable the controller to activate or cancel any of the stored programs simply add or remove the check marks by underscoring the appropriate boxes using or and pressing . Repeat the steps as needed and underscore OK and press to change valve options screen.

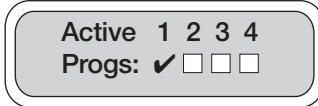

Note: Scheduled programs will not run unless you activated the appropriate program number in this screen.

This setting has two options for each valve.

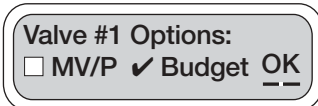

Option one MV/P: if checked the valve # will operate with installed master valve or pump. To switch on an installed MV/P use or to underscore MV/P and press to checkmark the box then underscore OK and press to move to the next screen or...

Option two: if checked the valve # will be affected by the monthly budget setting. All valves are budgeted by default, if you wish to deactivate the budget, repeat the steps to uncheck the marks under budget. Press and underscore OK. Repeat the same procedure for the remaining valves then underscore OK and press to move to the next screen.

Example if master valve has been installed: Switch on MV/P by simply adding a checkmark to the box near MV/P using or to underscore MV/P and press then , underscore OK and press to move to the next valve.

This setup indicates whether or not a sensor is activated and in use: if you install a sensor, use or to underscore Yes and press the button, then press or to underscore OK and press to enter sensor location

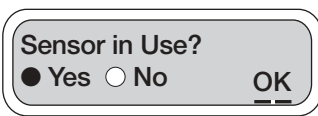

This setup indicates a sensor location.

If you selected YES in the "sensor in use" screen, you must indicate which station will have the SKIT and sensor(s) connected to it. Press or to underscore MV/P or other, press , then use or to underscore OK and press again to go to next screen and specify which station the sensor(s) is/are connected.

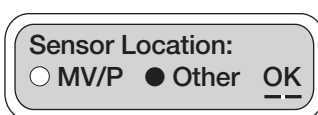

24. SETUP SYSTEM...continued

* If you use MV/P, sensor is connected to the master valve, if "Other" the sensor is connected to one of your stations

If you selected "Other" you must now specify which station number the sensor(s) is/are connected to. Press or to underscore the number and press or to enter the correct station #. Then press or to underscore OK and press to go to sensor governing.

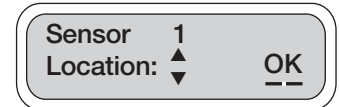

At this screen you can set up any or all of the installed valves to be switched off, when the sensor is triggered. Checkmark the boxes next to the station numbers that you wish to be governed by the sensor by using or and underscore the appropriate box, by pressing to checkmark the box then underscore OK using or and press to go to change password screen.

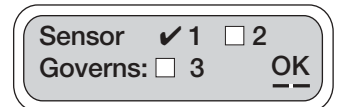

If an installed switch type sensor is triggered, any valve that is checkmarked and is currently "ON" will complete its programmed runtime. All further valve operations will be prevented until the sensor deactivates and allows watering again.

You may change the default password (AAA) to any three-digit combination of letters or numbers.

Just underscore Yes, using or , then press the to underscore OK using or and press to enter your new password screen.

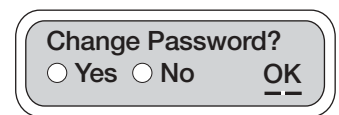

Enter your new password: Press or to underscore the digits you want to change, use or buttons to change the password. When finished, write down the password so as not to forget it.

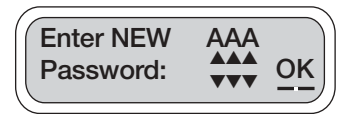

Underscore OK using or and press to exit. This will bring you back to the Setup System screen. Press to QUIT the programming session.

Remember that any person who makes changes to the watering schedule or the setup, needs to enter the new password;

If you're ready to quit programming, press and remove the LEIT KEY.

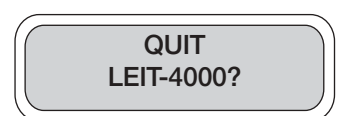

24. SETUP SYSTEM...continued

If the above screens have been completed successfully, your LEIT 4000 is now fully operational 24 hours a day!

Remove
LEIT-Key

25. SERVICE CALL (MAIN INSTALLATION PROBLEMS)

Make sure static main water pressure at the valve is below 150 PSI

Make sure you are using the proper LEMA actuator with your valve and controller

Make sure the valve opens and closes using the manual operation

25.1. CHECK THE LEIT CONTROLLER

To verify that the controller is operating correctly, insert the LEIT key and scroll to

Check Status mode. Verify if the controller accumulates the time correctly for past and current month, if the controller accumulates correctly go to #25.2.

25.2. CHECK THE LEMA ACTUATOR

Program the controller in Manual Run mode for 2 to 4 minutes, remove the LEIT Key and check if all the valves are operating. If you have a problem with a valve, troubleshoot as follows:

If the valve does not open, go to #25.3 (common information) or,

If the valve does not open (but you have the sense of hearing the actuator plunger latched) go to #25.4 (how to deal with a valve when the plunger is latched and the valve stays closed)

If the valve opens and stays open, go to #25.5 (how to deal with valves that stay open)

25.3. PROBLEMS WITH VALVES THAT DO NOT OPEN (COMMON INFORMATION)

Verify the LEMA actuator operates correctly by removing the actuator from the valve; make sure that the installation steps were followed correctly. Make sure that the correct actuator model is used with the correct adaptor.

Make sure wires are connected correctly to the controller and to the valve

Verify water proof connectors are installed correctly; if needed, remove and check water proof connectors, when testing for contact between the controller and the LEMA actuator

Test the wires from the controller to the actuator to verify connectivity. Remove the hot and common wires from the controller and use a 9-volt battery to see that the LEMA actuator plunger is latched and stays latched. If the plunger stays latched, the controller and the LEMA actuator are operating correctly, if not go to #25.4

25.4. PROBLEMS WITH A LEMA ACTUATOR PLUNGER

- a. Remove the LEMA actuator from the valve and turn the actuator so you can see the plunger
- b. Program the controller in manual mode for 2 to 4 minutes, remove the key and move to the valve with the problem and see if the actuator plunger is latched, if the actuator plunger is latched and stays latched for the program duration, then the actuator is working correctly, if it is unlatched go to c
- c. If the plunger latches and then pops out of the actuator before the end of the pre-programmed duration, you have a problem with the plunger spring. Remove the plunger and insert a new plunger. Repeat the test and make sure the plunger stays latched for the pre-programmed duration and that it pops out at the end of the cycle.
- d. After changing the plunger, install the LEMA actuator and perform another test to verify that the LEMA actuator is working correctly

24. SERVICE CALL...continued

25.5. PROBLEMS WITH VALVES THAT STAY OPEN

Normal 2-way valve operation is normally closed, if water is running when the controller is off, the problems are either the plunger rubber sleeve is worn out or the adapter is not threaded all the way to the valve port and is allowing water to pass between the inlet passage of the solenoid housing and the adaptor. Confirm the following:

If the valve stays open, verify that the adapter in use is the correct adapter, make sure the "O" rings are in the proper place and verify that the lower tip of the adapter that is in contact with the valve port is not damaged and that no water leaks between the adapter and the valve port.

If the valve still stays open, use a tool to turn and tighten the adapter until the valve will close and water will stop flowing.

26. TROUBLESHOOTING YOUR CONTROLLER

26.1 MECHANICAL PROBLEMS:

The LEIT 4000 does not lock firmly to the mounting column.

Check the following:

- 1) Are you using the required MCOL 4000?
- 2) Are you using the correct locking spacer and mounting screw assembly?
- 3) Have you tightened the mounting screw firmly enough with the hex key?

The LEMA actuator assembly will not correctly attach to valve or, when attached, leaks water from stem or adaptor.

Check the following:

- 1) Check if the actuator model # is correct for valves being used (see page 7).
- 2) Make sure stem and/or adaptor are firmly assembled together with o-rings in place and firmly screwed into the valve.

26.2 ELECTRICAL PROBLEMS:

With the LEIT Key plugged into the controller after 2 minutes there is no visible display.

Check the following:

- 1) Check the battery in the LEIT Key and replace if necessary.
- 2) Make sure the LEIT Key is plugged in all the way.

Some or all valves fail to operate when using "Manual Run". (Systems NOT USING a master Valve/Pump)

Check the following:

- 1) Make sure that the red (hot) wires of the actuators are spliced to the hot field wires leading to your controller.
- 2) Make sure all the white (common) wires of the actuators are connected to the common field wire leading back to your controller.
- 3) Insert all field wires (with 3/10" of insulation stripped from the end of the wires) firmly into the valve connector and tighten the appropriate screws so as to ensure good connection.
- 4) Make sure that the wires are corrosion free, the joints are tight and made waterproof.
- 5) Are you using the correct actuators for your valves? (see page 7)

- 6) Make sure that the wire length has not exceeded the maximum wire run for the gauge of wire being used (see distance, page 3).
- 7) Make sure that there is adequate water pressure.
- 8) Make sure that the water pressure is not too high (over 150 psi). Use a pressure regulator if necessary.
- 9) Make sure that the water piping system is not clogged or plugged.

Expansion controllers only: (LEIT 4012E and LEIT 4016E)

- 10) Verify that the labels of your actuators state that you are using "LEMA 1500S, Standard" and LEMA 1500E, Expansion" series actuators. The older type actuators of the "LEMA 1500-4 non-sensing" series will not work with expansion controllers.

Some or all valves fail to operate when using "Manual Run". (Systems USING a Master Valve/Pump)

Check the following:

- 1) All of above reasons for failure may apply as well.
- 2) Check the functionality of the master valve. If the master valve does not operate, there will be no water pressure for the other valves.
- 3) Make sure the red (hot) wire coming from the master valve is plugged into the "Master Valve/P" position on your LEIT 4000.

One valve will come on together with a second valve but not independently (systems NOT USING a Master Valve/Pump)

Check the following:

- 1) Check if the red (hot) wires are plugged into the designated valve slots (labeled with the Valve Number). If one of the wires is connected to the designated Master Valve/Pump position, it will not operate independently, but will come on when any other valve operates.

Expansion controllers only: (LEIT 4012E and LEIT 4016E)

- 2) You paired up the hot wires of two standard or two expansion actuators instead of 1 standard and 1 expansion actuator. If actuators of identical type share the same hot wire they can not be operated individually. Make sure that you follow the instructions on how to connect standard and expansion actuators to the controller. (see page 11).

Valves switch on but not off.

Check the following:

- 1) Check that the label on top of each of the actuator bodies is facing upwards.
- 2) Make sure that the nut on the actuator assembly is tightened firmly. Finger tight is unacceptable. Do not over tighten.
- 3) Make sure that the field hot & common wire connections are not reversed.

26.3 PROGRAMMING PROBLEMS:

The valves will come on using the "Manual Run" feature but will not water automatically.

Check the following:

- 1) "Rain Stop" is active. To reactivate the program schedule, go into the Main Menu "Rain Stop/Restart" and cancel the Rain Stop (see pages 16 and 20)
- 2) No programming schedules have been entered yet. Go into Main Menu "Setup Schedule" and enter a program (see pages 18 and 23)

- 3) You programmed the controller, but did not ACTIVATE the programs. Go into Main Menu "Setup System" and activate the desired programs (see pages 20 and 23).
- 4) The programmed runtime of the stations is set to "0" duration. Go into Main Menu "Setup Schedule" and alter runtime (see manual page 19).
- 5) You are not using a sensor, but you programmed the system for sensor operation. Go into Main Menu "Setup System" and check that sensors are unused (see pages 20 and 23).
- 6) A sensor is hooked up to the system and is in a state that inhibits watering.

A programmed schedule does not complete a watering cycle.

Check the following:

- 1) Make sure the different programs are not overlapping each other. If any of the programs should not be finished by the start time of the following program, the previous program will be terminated.
- 2) Make sure there is enough time between the programs and/or start times to budget your watering time (up to 200% possible) (see pages 18 and 20)

The password has been changed or forgotten:

Please call DIG Customer Service with the Serial Number of your controller to find out the factory password specific to your controller.

If the provided solutions have not solved your problems, please call DIG Customer Service (800-322-9146) for further technical support.

Please note that tampering with the controller or even attempting to take it apart, will VOID any warranty your product might be eligible for.

27. WARRANTY

DIG Corp. warrants to its customers who have purchased LEIT products, from an authorized DIG distributor, that its products will be free from original defects in material and workmanship for a period of two (2) years, from the date of original purchase except as to product described in subsection (A).

If any apparent defect arises under normal use and service in the LEIT product within the warranty period, DIG at its sole discretion, shall have the option to repair or replace part or all of the original product free of charge after return of such product at user expense, authorized in writing by DIG Corp. If a product is replaced, the replacement product will be covered for the remainder of the warranty period dating from the original purchase

(A). LEIT Controllers with LEIT stainless steel enclosures warranted to be free from original defects in material and workmanship for a period of two (2) years, from the date of original purchase, except for stainless steel enclosures purchased prior to 1/8/ 2001, these units will be warranted to 12/31/2004

This warranty applies only to the DIG LEIT product line, which are installed as specified and used for irrigation purposes. This warranty applies only to products, which have not been altered, modified, damaged, misused or misapplied. This warranty does not cover products adversely affected by the system into which the products are incorporated, including improperly designed, installed, operated, or maintained systems. This warranty does not apply to blockage of solenoids due to use of water containing corrosive chemicals, electrolytes, sand, dirt, silt, rust, scale, algae, bacterial slime or other organic contaminants.

Tampering with a product (including, but not limited to attempting to disassembly) will void any warranty the product might otherwise be eligible for. In no event shall DIG's liability exceed the selling price of the product. DIG is not liable for consequential, incidental, indirect or special damages, including but not limited to the labor to inspect, remove or replace products, vegetation loss, loss of energy or water, cost of substitute equipment or services, property damage, loss of use or loss of profits; nor is DIG liable for economic losses, consequential damages or damage to property arising out of installer's negligence or based on strict liability in tort. The user and/ or trade customer agrees to the limitations and exclusions of liability of this warranty by purchase or use of DIG products. . No representative, agent, distributor or other person has the authority to waive, alter, or add to the printed provisions of this warranty, or to make any representation of warranty not contained here.

Some states do not permit the exclusion or limitation of incidental or consequential damages or of implied warranties. Therefore, some of the above exclusions or limitations may not apply to you.

This warranty on LEIT products is given expressly and in place of all other expressed or implied warranties of merchantability and fitness for particular purpose, and this warranty is the only warranty on LEIT products line made by DIG Corp

For more information or For LEIT 3 Years Extended Warranty see your DIG Corp distributor or call 1800-322-9146

1-800-822-9146 FAX 760-727-0282

SAVE FOR YOUR RECORDS

Valve No.	Valve Location	Irrigation Program		Irrigation Duration (minutes, hours)	Program			Daily Start Times				
		Weekly	Cyclical		1	2	3	1	2	3		
1		M, Tu, W, Th, F, Sa, Su										
2		M, Tu, W, Th, F, Sa, Su										
3		M, Tu, W, Th, F, Sa, Su										
4		M, Tu, W, Th, F, Sa, Su										
5		M, Tu, W, Th, F, Sa, Su										
6		M, Tu, W, Th, F, Sa, Su										
7		M, Tu, W, Th, F, Sa, Su										
8		M, Tu, W, Th, F, Sa, Su										
9		M, Tu, W, Th, F, Sa, Su										
10		M, Tu, W, Th, F, Sa, Su										
11		M, Tu, W, Th, F, Sa, Su										
12		M, Tu, W, Th, F, Sa, Su										
13		M, Tu, W, Th, F, Sa, Su										
14		M, Tu, W, Th, F, Sa, Su										
15		M, Tu, W, Th, F, Sa, Su										
16		M, Tu, W, Th, F, Sa, Su										